

LONKING 龙工

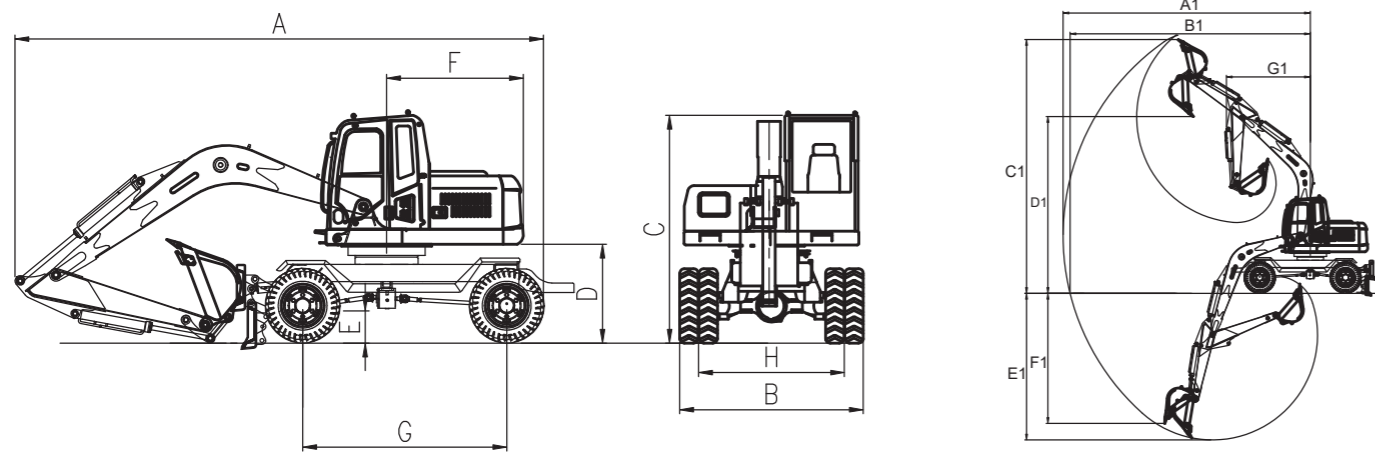

CDM6075W WHEEL EXCAVATOR

TECHNICAL PARAMETERS

	Name	Data
Basic	Operating weight	7000 kg
	Boom length	3300 mm
	Arm length	1850 mm
	Standard bucket	0.2-0.3 m ³
	Max.Travel speed	25 km/h
	Max.Swing speed	11 rpm
	Grade ability	30°(58%)
	Tire type	7.50-16
	Max.Traction force	45 kN
Engine	Engine model	YC4DK75
	Rated power	55 kW/2200 rpm
	Displacement	3.621 L
	Fqt fuel quantity	≥4 L/h
	Fuel tank	110 L
Hydraulic	Max.Flow(total)	150 L/min
	Max.Working pressure	25 MPa
	Max.Digging force	45 kN
	Hrdraulic oil tank	110 L
Working Range	A1 Max.Digging reach	6400 mm
	B1 Max.Ground digging reach	6200 mm
	C1 Max.Digging height	6800 mm
	D1 Max.Dumping height	4900 mm
	E1 Max.Digging depth	3300 mm
	F1 Max. Vertical digging depth	2900 mm
	G1 Min. Working radius	2300 mm
Overall Dimension	Transport demission (A×B×C)	5800×2100×2900 mm
	D Counterweight ground clearance	1060 mm
	E Min. Ground clearance	250 mm
	F Tail swing radius	1980 mm
	G Axle base	2400 mm
	H Wheel base	1660/1580 mm

CONFIGURATION

Name	Type
Engine	Stage 3 emission
Main valve	Multiple unit
Main pump	Piston Type
Swing motor	Piston Type
Gearbox	MT(5 speed)
Travel motor	Heavyduty

OPTIONAL

Custom bucket
Hydraulic hammer
Quick coupler
Hydraulic clamp
Magnetic chuck
Supporting leg
Rear view camera

PRODUCT FEATURES

Strong & Powerful Engine. Water Cooled, Four Stroke, HPCR(BOSCH)
High Efficiency Dual Air and Fuel Filters
Parallel Radiator Cooling System
High efficiency and energy saving hydraulic system
LCD Monitor and Advanced Electronic Monitoring System
Safe and Comfortable Cab, Ergonomic Design
Working device adopts low alloy and high strength structural steel.
Standard with rear dozer, air conditioner



The following blank can be used for notes or comments.

For more information on Lonking products,
Please contact our local agent:

Lonking, Lonking CDM Series and their respective logos, as well as corporate identity in this leaflet are trademarks of Lonking Holdings Ltd., and may not be used without written permission.

2022/03

Specifications and design are subject to change without prior notice.
Machines shown may not include optional accessories.

OPERATING WEIGHT:	7000kg
ENGINE POWER:	55kW
BUCKET CAPACITY:	0.2-0.3m ³
TRAVEL SPEED:	25km/h