

# LONKING 龙工

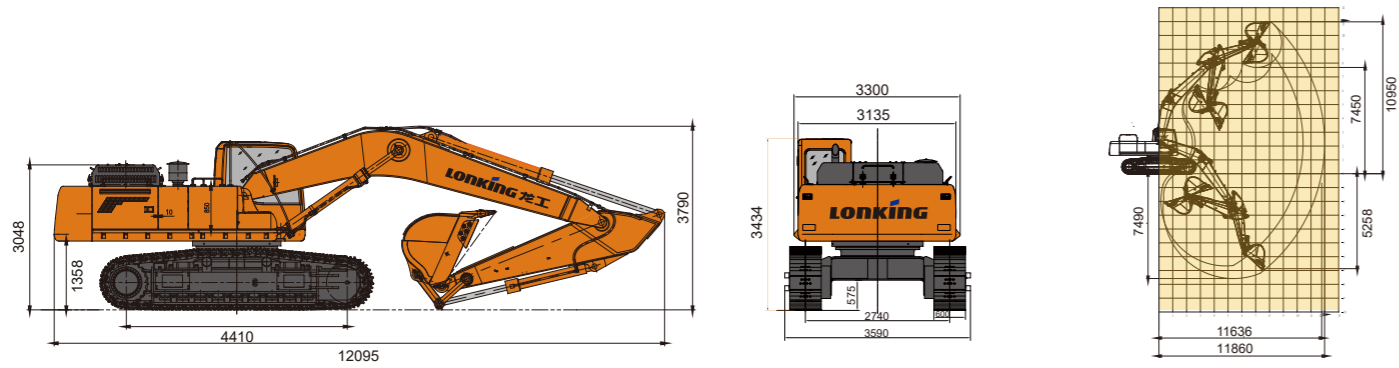

## TECHNICAL PARAMETERS

Name		Data
Basic	Operating weight	50500 kg
	Boom length	7000 mm
	Arm length	3000 mm
	Standard bucket	2.6 m <sup>3</sup> ( Rock )
	Max.Travel speed	3.4/5.3 km/h
	Max.Swing speed	8 rpm
	Grade ability	35°(70%)
	Ground pressure	87.1 kPa
	Max.Traction force	396 kN
Engine	Engine model	6WG1-XDHAG-03-C3
	Rated power	300 kW/1800 rpm
	Max.Torque	1898/1400 N.m/rpm
	Displacement	15.681 L
	Fuel tank	680 L
Hydraulic	Max.Flow(total)	360×2 L/min
	Max.Working pressure	34.3 MPa
	Max.Pilot pressure	3.9 Mpa
	Max.Arm digging force	245 kN(ISO)
	Max.Bucket digging force	287 kN(ISO)
	Hrdraulic oil tank	480 L
Chassis	Track width	600 mm
	Track shoes number	50( each side)
	Carrier rollers number	2( each side)
	Track rollers number	9( each side)
Electric	System vottage	24 V
	Battery capacity	24 V,200 Ah×2

## PRODUCT FEATURES

Isuzu Turbocharged Engine, Large Displacement, Strong Power
Adopt Independent Cooling System to Reduce Power Loss and Noise
Advanced Hydraulic System
Combined C type closed frame improves rigidity and strength of rotary platform.
Comfortable ROPS Cabin with 2.7m <sup>3</sup> Operational Space
No Frame Cab Glasses to Enlarge Operation Field of View
Double-rib Rock Track Shoes, Chassis Reinforcement, More reliable and Wear-resistant
Heavy-duty Working Device with High Strength Low Alloyed Steels

## OPTIONAL

Breaking hammer & pipeline
Work warning light
Walking alarm
Front protecting net
700mm triple grouser shoes
800mm triple grouser shoes

# CDM6490F

## HYDRAULIC EXCAVATOR

Perfect Quality, High Benefit



- OPERATING WEIGHT: 50500kg
- ENGINE POWER: 300kW
- BUCKET CAPACITY: 2.6m<sup>3</sup>
- TRAVEL SPEED: 3.4/5.3km/h

The following blank can be used for notes or comments.

**For more information on Lonking products,  
Please contact our local agent:**