

## CONFIGURATION

Hydraulic Gearbox	Tilting Cylinder Latching Valve
Electric Reversing	Combination Instrument
Overhead Guard	Working Hour Meter
Top Rain Shelter	Oil Content Meter
Pedal Rubber	Water-thermometer
Semi-suspension Seat	Charging Indicator
Wide Field Mast (2 Stage)	Neutral Position Switch
Fork Carriage	Oil Pressure Warning
Backrest	Electric Horn
Standard Forks	LED Signal Lamp
Adjustable Steering Column	Reversing Buzzer
Lifting and Tilting Joysticks	Backup Mirror
Two Piece Multiplex Valve	Traction Pin
Full-hydraulic Power Steering	Tool Box

## OPTIONAL

Mechanical Gearbox	Fire Extinguishing Muffler
Mechanical Reversing	Driving OPS
Solid Tires	Full Set OPS (Including drive and lift)
Cabin	Full Set LED Lamps
Working Warning Light	Reversing Voice Horn
Suspension Seat	Overspeed Alarm, 10km/h
Cold A/C	Electric Fan
Warm-air Blower	Sound-light Alarm
Front Windscreen	Rear Working Lamp
High Level Exhaust	Lengthen Fork Jacket
Double Air Filter(S4S NA)	Tilting Cylinder Sleeve
Oil Bath Air Filter	Steering Cylinder Sleeve
Widen Fork Frame	Custom Colors
Multiple Work Attachments	

## PRODUCT FEATURES

**Attractive Appearance**  
Smooth and novel styling, balance weight with car design elements, strong personality, dynamic.

**Lowering Energy Consumption**  
Optimized design of load sensing hydraulic system reduces vehicle fuel consumption Effectively.

**Operating Comfort**  
Adopted interactive ergonomic design to improve operating comfort. Equipped with wide field of view mast to improve driver's field of view.

**Sensitive and Stable**  
Integral steering device, more sensitive directivity, smooth operation, more stable quality.

**Convenient Maintenance**  
Interior space of car body is more spacious Parts Positions are more reasonable. Maintainability of machine is better.

**Safety and Reliable**  
High-strength integral hood and one-body impact molding overhead guard.

The following blank can be used for notes or comments.

**For more information on Lonking products,  
Please contact our local agent:**

Lonking, Lonking LG Series and their respective logos, as well as corporate identity in this leaflet are trademarks of Lonking Holdings Ltd., and may not be used without written permission.  
2020/04

Specifications and design are subject to change without prior notice.  
Machines shown may not include optional accessories.

# LONKING 龙工

## LG20/25/30/35DT III BALANCEWEIGHT TYPE FORKLIFT TRUCK WITH ENGINE Efficiency Rules the Future



	LG20DTIII	LG25DTIII	LG30DTIII	LG35DTIII
Rated Capacity (kg)	2000	2500	3000	3500
Load Center (mm)	500	500	500	500
Power Type	Diesel	Diesel	Diesel	Diesel

## OVERALL SPECIFICATIONS

Type	No.	Item	Code	Unit	Data			
Identification	1.01	Manufacturer			LONKING			
	1.02	Model			LG20DTIII	LG25DTIII	LG30DTIII	LG35DTIII
	1.03	Power type			Diesel			
	1.04	Rated capacity	Q	kg	2000	2500	3000	3500
	1.05	Load center	J	mm	500	500	500	500
Dimensions	2.01	STD Max height (with backrest)		mm	3965	3965	4210	4237
	2.02	STD Max lifting height	h1	mm	3000	3000	3000	3000
	2.03	Overhead guard height	h4	mm	2130	2130	2150	2150
	2.04	Overall length (with fork)	L1	mm	3670	3670	3850	3898
	2.05	Wheelbase	L2	mm	1650	1650	1750	1750
	2.06	Front overhang	L3	mm	448	448	487	498
	2.07	Rear overhang	L4	mm	500	500	550	580
	2.08	Min.ground clearance (Frame/Mast)	m1/m2	mm	160/135	160/135	165/132	165/132
	2.09	Overall width	W1	mm	1165	1165	1250	1250
	2.10	Adjusting range of fork (outside)		mm	240-1040	240-1040	255-1055	255-1055
	2.11	STD Fork size (L5*W*T)		mm	1070×120×40		1070×125×45	1070×125×50
	2.12	Front wheel tread	S	mm	970	970	1030	1030
	2.13	Rear wheel tread	P	mm	980	980	980	980
	2.14	Min.turning radius	R1	mm	2300	2300	2520	2530
	2.15	Min aisle width for pallet 1000×1200,crossways		mm	3950	3950	4200	4225
	2.16	Min aisle width for pallet 800×1200,lengthways		mm	4148	4148	4407	4428
Tires	3.01	Wheels number, front/rear (X=driven wheels)			X=2/2			
	3.02	Tires type			Pneumatic			
	3.03	Tires size, front			7.00-12-12PR		28×9-15-14PR	
	3.04	Tires size, rear			6.00-9-10PR		6.50-10-10PR	
Other Details	4.01	Max.traveling speed, loaded/unloaded		km/h	18.5/20	18.5/20	18.5/20	18.5/20
	4.02	Max.lifting speed, loaded/unloaded		mm/s	480/510	480/510	450/485	450/485
	4.03	Lowering speed, loaded/unloaded		mm/s	Loaded≤ 600/Unloaded≥ 300			
	4.04	Max.gradient, loaded/unloaded		%	20	20	20	20
	4.05	STD operating weight (with oil & water)		kg	3250	3600	4160	4630
	4.06	Axles loading,front/rear (loaded)		kg	4725/525	5490/610	6520/640	7265/865
	4.07	Axles loading,front/rear (unloaded)		kg	1300/1950	1440/2160	1680/2480	1760/2870
	4.08	Service brake			Mechanical/Power brake-pedal			
	4.09	Parking brake			Mechanical-hand brake lever			
	4.10	Drive type			Mechanical/Automatic			
	4.11	Fuel tank capacity		L	50	50	60	60
	4.12	Battery votage/capacity		V/Ah	12/80			

## ENGINE OPTIONAL

Engine Model	Emission	Manufacturer	Rated Power	Max.Torque	Bore/Cylinders Number/Displacement	Fuel Consumption	Applicable
C490BPG-47	Euro IIIA	XINCHAI	36.8kW/2650rpm	156N.m/1800rpm	90mm/4/2.67L	230g/kW.h	2-3T
C240	CHN III/Euro IIIA	ISUZU	35.4kW/2500rpm	137N.m/1800rpm	86mm/4/2.369L	292g/kW.h	2-3T
C490BPG-225	CHN II	XINCHAI	36.8kW/2200rpm	156N.m/1800rpm	90mm/4/2.67L	230g/kW.h	2/2.5T
A498BT1-58	Euro IIIA	XINCHAI	36.8kW/2400rpm	180N.m/1800rpm	98mm/4/3.17L	230g/kW.h	3/3.5T
S4S-474	Euro IIIA	MITSUBISHI	35.3kW/2300rpm	176N.m/1800rpm	120mm/4/3.331L	225g/kW.h	3/3.5T
4JG2	Euro II	ISUZU	46kW/2450rpm	186N.m/1700rpm	95mm/4/3.059L	265g/kW.h	3/3.5T
3E22YG51	Euro V	XINCHAI	44.8kW/2400rpm	210N.m/1800rpm	94mm/3/2.23L	255g/kW.h	2-3.5T

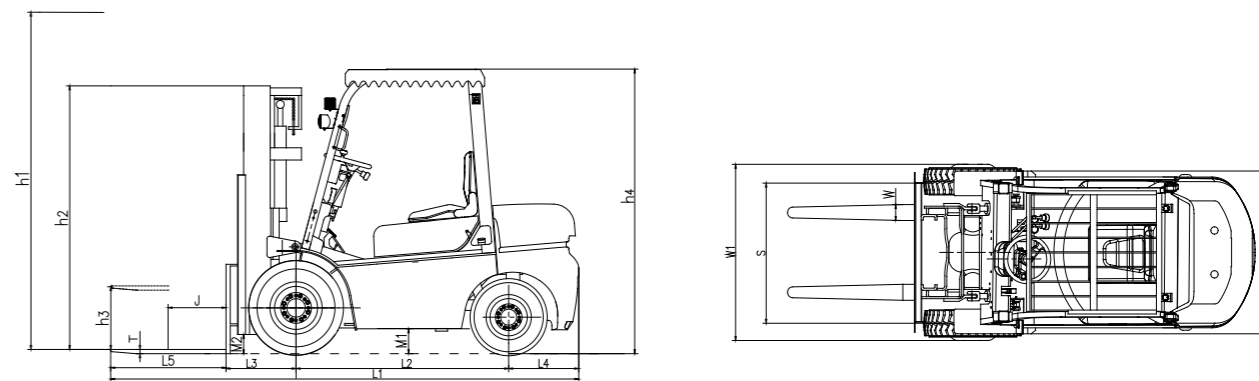

## MAST SPECIFICATIONS

### 2 Stage Standard Mast-Super Wide Field

Mast Model	h1 Max Lifting Height(mm)	Load Capacity (J=500mm) (kg)				h2 Lowered Mast Height (mm)			h3 Free Lifting Height, without backrest (mm)			Mast tilt α/β (°)
		2T	2.5T	3T	3.5T	2-2.5T	3T	3.5T	2-2.5T	3T	3.5T	
M200	2000	2000	2500	3000	3500	1500	1555	1670	150	145	150	6/12
M250	2500	2000	2500	3000	3500	1750	1805	1920	150	145	150	6/12
M270	2700	2000	2500	3000	3500	1850	1905	2020	150	145	150	6/12
M300	3000	2000	2500	3000	3500	2000	2055	2170	150	145	150	6/12
M330	3300	2000	2500	3000	3500	2150	2205	2320	150	145	150	6/12
M350	3500	2000	2500	3000	3500	2250	2305	2420	150	145	150	6/12
M370	3700	2000	2500	3000	3500	2350	2405	2520	150	145	150	6/12
M400	4000	2000	2500	2950	3200*3400	2550	2605	2720	150	145	150	6/6
M425	4250	1850*2000	2250*2500	2850*3000	3100*3300	2675	2730	2845	150	145	150	6/6
M450	4500	1600*1900	2100*2400	2600*2800	2900*3100	2800	2855	2970	150	145	150	6/6
M475	4750	1400*1800	1900*2200	2350*2600	2700*2900	2925	2980	3095	150	145	150	6/6
M500	5000	1300*1700	1600*1900	2100*2400	2400*2750	3050	3105	3220	150	145	150	6/6
M550	5500	1200*1500	1200*1700	2000*2400	2200*2400	3350	3405	3520	150	145	150	3/6
M600	6000	1000*1300	900*1400	1500*2000	1800*2200	3600	3655	3770	150	145	150	3/6

Note:\*\*\*\* means capacity of double front wheels.

### 2 Stage Free Mast-Super Free Lifting Height

Mast Model	h1 Max Lifting Height(mm)	Load Capacity (J=500mm) (kg)				h2 Lowered Mast Height (mm)			h3 Free Lifting Height, without backrest (mm)			Mast tilt α/β (°)
		2T	2.5T	3T	3.5T	2-2.5T	3T	3.5T	2-2.5T	3T	3.5T	
ZM200	2000	2000	2500	3000	3500	1555	1555	1670	1085	860	895	6/12
ZM250	2500	2000	2500	3000	3500	1805	1805	1920	1335	1110	1145	6/12
ZM270	2700	2000	2500	3000	3500	1905	1905	2020	1435	1210	1245	6/12
ZM300	3000	2000	2500	3000	3500	2055	2055	2170	1555	1360	1395	6/12
ZM330	3300	2000	2500	3000	3500	2205	2205	2320	1735	1510	1545	6/12
ZM350	3500	2000	2500	3000	3500	2305	2305	2420	1835	1610	1645	6/12
ZM370	3700	/	/	3000	3500	/	2405	2520	/	1710	1745	6/12
ZM400	4000	2000	2500	2850	3250*3500	2605	2605	2720	2135	1910	1945	6/6
ZM450	4500	1600*1900	2100*2400	2600*2800	2900*3100	2855	2855	2970	2385	2160	2195	6/6

Note:\*\*\*\* means capacity of double front wheels.2-2.5T free lifting height reduces 293mm with backrest.3T free lifting height reduces 594mm with backrest.3.5T free lifting height reduces 454mm with backrest.

### 3 Stage Free Mast-Super Free Lifting Height

Mast Model	h1 Max Lifting Height(mm)	Load Capacity (J=500mm) (kg)				h2 Lowered Mast Height (mm)			h3 Free Lifting Height, without backrest (mm)			Mast tilt α/β (°)
		2T	2.5T	3T	3.5T	2-2.5T	3T	3.5T	2-2.5T	3T	3.5T	
ZSM360	3600	1900	2400	2900	3300	1805	1870	1870	1240	1090	1112	6/6
ZSM400	4000	1800*1900	2300	2800	3300	1930	2005	2005	1365	1225	1230	6/6
ZSM430	4300	/	/	2700*2900	2900*3100	/	2100	2100	/	1320	1325	6/6
ZSM450	4500	1600*1800	2000*2300	2500*2700	2800*3000	2118	2170	2170	1553	1390	1395	6/6
ZSM480	4800	1250*1700	1700*2000	2250*2450	2500*2750	2205	2270	2270	1640	1490	1495	6/6
ZSM500	5000	1100*1600	1500*1800	2100*2300	2300*2600	2305	2335	2335	1740	1555	1560	6/6
ZSM550	5500	/	/	1500*2000	1700*2200	/	2500	2500	/	1720	1725	3/6
ZSM600	6000	600*1100	800*1300	1200*1800	1300*2000	2655	2720	2720	2090	1940	1945	3/6
ZSM650	6500	400*800	600*1000	900*1500	1000*1600	2870	2910	2910	2305	2130	2135	3/3

Note:\*\*\*\* means capacity of double front wheels.2-2.5T free lifting height reduces 293mm with backrest.3T free lifting height reduces 602mm with backrest.3.5T free lifting height reduces 466mm with backrest.