

## DIMENSION

All Dimensions are Approximate. Dimensions May Vary with Bucket. Refer to Operating Specifications.

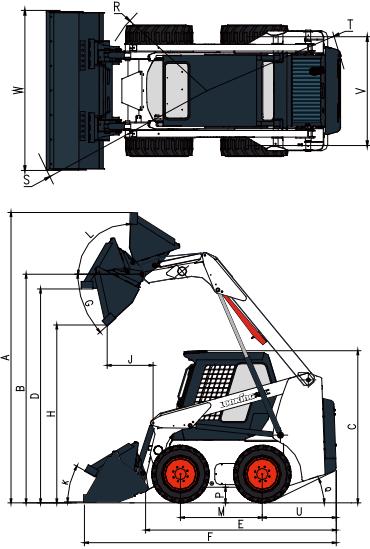

NO.	DESCRIPTION	UNIT	DATA
A	Max.Operation Height	mm	3850
B	Bucket Pin Height	mm	2920
C	Cab Roof Height	mm	2000
D	Max.Height At Bucket Leveled	mm	2730
E	Length Without Attachment	mm	2420
F	Length With Standard Bucket	mm	3320
H	Dumping Height	mm	2180
J	Reach Rollback	mm	790
M	Wheelbase	mm	1050
P	Ground Clearance	mm	210
R	Front Turning Radius Without Attachment	mm	1200
S	Front Turning Radius	mm	2060
T	Rear Turning Radius	mm	1520
U	Tail Length	mm	960
V	Center Distance between Two Wheels	mm	1240
W	Bucket Width	mm	1530
G	Dumping Angle At Max.Height	°	39
K	Bucket Angle On Ground	°	28
L	Bucket Rollback Angle At Max.Height	°	94
Q	Start Angle	°	27

## TECHNICAL PARAMETERS

BASIC	Operating Weight	2800kg
	Rated Payload	752kg
	Bucket Capacity	0.43m <sup>3</sup>
	Tipping Load	1504kg
	Breakout Force	20.3kN
	Traction Force	18.9kN
	L×W×H	3320×1530×2000
ENGINE	Engine Model	V2403-M-D-FET04
	Rated Power	36/2600kW/rpm
	Displacement	2.434L
	Fuel consumption	10L
	Stroke	87mm
	Bore	102.4mm
	Emission Standard	Euro IIIA
HYDRAULIC SYSTEM	Hydraulic Flow – Standard	74L/min-2600rpm
	Type	Mechanical Servo
	Hydraulic Pressure– Standard	21MPa
DRIVE TRAIN	Travel Speed -F&R	11.5km/h
	Tyre	10-16.5NHS
ELECTRIC	Voltage(V)	12 V
	Capacity(Ah)	120 Ah
SERVICE REFILL CAPACITY	Chain Box, Each Side	9L
	Cooling System	12L
	Engine Crankcase	8L
	Fuel Tank	83L
	Hydraulic Tank	65L

## OPTIONAL

Cold Start	Tree Planter
Open Cab	Four In One Bucket
Solid Tyre	Detachable Bucket Tooth
Centralized pressure measurement	Detachable Bucket Blade
Rearview mirror heating function	Spiral Drill
Warm Air Blower	Closed Sweeper
Excavator	Snow Blade
Bevel Sweeper	Fork

### Function Description:

- 1.Integrated loader frame, higher intensity and better stability.
- 2.Kubota strong power engine,which meets EU Stage IIIA emission standard.
3. It adopts original and imported hydraulic system with stable reliability.
- 4.Cab adopts big angle and backward dump design, backward dump leaves bigger space for repair and convenient for maintenance.
- 5.It complies with international safety standard FOPS/ROPS of high intensity cab, which has bigger space and is more comfortable.
- 6.Hydraulic operation system adopts design of electric control self-lock and interlock to reduce misoperation to make the system safer.
- 7.It adopts quick changing device commonly used internationally, which can change all kinds of attachments quickly and conveniently. Hydraulic quick connector matches attachments from most manufacturers.
- 8.Compared with similar types, it has characteristics of narrow loader body.

The following blank can be used for notes or comments.

**For more information on Lonking products,  
Please contact our local agent:**

# Lonking 龙工

## CDM307

### Lonking Skid Steer Loader

Efficiency Rules the Future



- ENGINE MODEL : V2403-M-D-FET04
- RATED POWER: 36kW/2500rpm
- OPERATING WEIGHT: 2700kg
- RATED PAYLOAD: 752kg
- BUCKET CAPACITY: 0.43m<sup>3</sup>