

DIMENSION

All Dimensions are Approximate. Dimensions May Vary with Bucket. Refer to Operating Specifications.

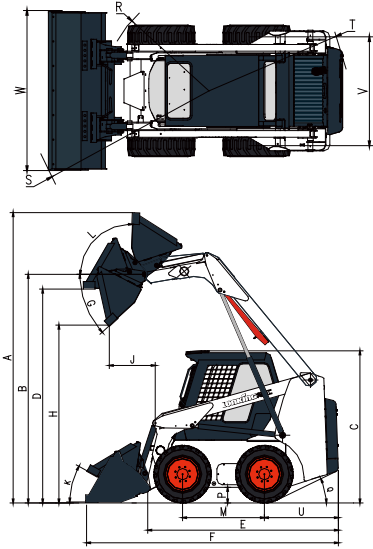

NO.	DESCRIPTION	UNIT	DATA
A	Max.Operation Height	mm	3880
B	Bucket Pin Height	mm	3060
C	Cab Roof Height	mm	2000
D	Max.Height At Bucket Leveled	mm	2870
E	Length Without Attachment	mm	2530
F	Length With Standard Bucket	mm	3460
H	Dumping Height	mm	2440
J	Reach Rollback	mm	610
M	Wheelbase	mm	1080
P	Ground Clearance	mm	180
R	Front Turning Radius Without Attachment	mm	1180
S	Front Turning Radius	mm	2050
T	Rear Turning Radius	mm	1580
U	Tail Length	mm	980
V	Center Distance between Two Wheels	mm	1320
W	Bucket Width	mm	1820
G	Dumping Angle At Max.Height	°	40
K	Bucket Angle On Ground	°	29
L	Bucket Rollback Angle At Max.Height	°	96
Q	Start Angle	°	28

TECHNICAL PARAMETERS

BASIC	Operating Weight	3500kg
	Rated Payload	1230kg
	Bucket Capacity	0.54m ³
	Tipping Load	2460kg
	Breakout Force	28.06kN
	Traction Force	25.9kN
	L×W×H	3460×1820×2000
ENGINE	Engine Model	V3600-T-E3B
	Rated Power	63kW/2600rpm
	Displacement	3.62L
	Fuel consumption	17.4L
	Stroke	98mm
HYDRAULIC SYSTEM	Bore	120mm
	Emission Standard	Euro IIIA
	Hydraulic Flow – Standard	91L/min·2600rpm
	Type	Mechanical Servo
DRIVE TRAIN	Hydraulic Pressure– Standard	21MPa
	Hydraulic Flow – High Flow	135L/min·2600rpm
	Loader Hydraulic Pressure	19 Mpa
ELECTRIC	Travel Speed -F&R	11.8km/h
	Tyre	12-16.5 NHS
SERVICE REFILL	Voltage(V)	12 V
	Capacity(Ah)	120 Ah
	Chain Box, Each Side	9L
CAPACITY	Cooling System	12L
	Engine Crankcase	9L
CAPACITY	Fuel Tank	91L
	Hydraulic Tank	65L

OPTIONAL

Cold Start	Snow Blower
Open Cab	Tree Planter
Solid Tyre	Four In One Bucket
Spiral Drill	Detachable Bucket Tooth
Excavator	Detachable Bucket Blade
Bevel Sweeper	Warm Air Blower
Closed Sweeper	Mass Flow System
Fork	Centralized pressure measurement
Snow Blade	Rearview mirror heating function

Function Description :

- 1.Integrated loader frame, higher intensity and better stability.
- 2.Kubota strong power engine,which meets EU Stage III A emission standard.
3. It adopts original and imported hydraulic system with stable reliability.
- 4.Cab adopts big angle and backward dump design, backward dump leaves bigger space for repair and convenient for maintenance.
- 5.It complies with international safety standard FOPS/ROPS of high intensity cab, which has bigger space and is more comfortable.
- 6.Hydraulic operation system adopts design of electric control self-lock and interlock to reduce misoperation to make the system safer.
- 7.It adopts quick changing device commonly used internationally, which can change all kinds of attachments quickly and conveniently. Hydraulic quick connector matches attachments from most manufacturers.
- 8.Compared with similar types, it has characteristics of narrow loader body, long wheelbase, high chassis, smaller steering radius, higher stability and stronger passing capacity.

**For more information on Lonking products,
Please contact our local agent:**

The following blank can be used for notes or comments.

Lonking 龙工

CDM312

Lonking Skid Steer Loader

Efficiency Rules the Future



- ENGINE MODEL : V3600-T-E3B
- RATED POWER: 63KW/2600rpm
- OPERATING WEIGHT: 3500kg
- RATED PAYLOAD: 1230kg
- BUCKET CAPACITY: 0.54m³